

AJ65FBTA42-16DTE CC-Link System Low Profile Waterproof Type Remote I/O Module User's Manual

● SAFETY PRECAUTIONS ●

(Read these precautions before using.)

When using this equipment, thoroughly read this manual. Also pay careful attention to safety and handle the module properly.

These precautions apply only to this equipment. Refer to the CPU module user's manual for a description of the PC system safety precautions.

These ●SAFETY PRECAUTIONS● classify the safety precautions into two categories: "DANGER" and "CAUTION".

DANGER	Procedures which may lead to a dangerous condition and cause death or serious injury if not carried out properly.
CAUTION	Procedures which may lead to a dangerous condition and cause superficial to medium injury, or physical damage only, if not carried out properly.

Depending on circumstances, procedures indicated by CAUTION may also result in to serious results.

In any case, it is important to follow the directions for usage.

Store this manual in a safe place so that you can take it out and read it whenever necessary. Always forward it to the end user.

[DESIGN PRECAUTIONS]

DANGER
<ul style="list-style-type: none"> ● When a communication error occurs in the data link, the communication error station will be in the following condition. Configure an interlocking circuit in a sequence program using the communication status information so that the safety of the overall system is always maintained. Accident may occur due to output error or malfunction. (1) Input points from remote I/O station will be all switched off. (2) Output points from remote I/O station will be all switched off. ● I/O could be switched on or off when a problem occurs in the remote I/O modules. So build an external monitoring circuit that will monitor any I/O signals that could cause a serious accident.

CAUTION
<ul style="list-style-type: none"> ● Use each module in an environment as specified in the "general specification" in the CPU module user's manual. Usage of the module outside the general specification range may cause electric shock, fire, malfunction, product damage or deterioration. ● Do not have control cables and communication cables bundled with or placed near by the main circuit and/or power cables. Wire those cables at least 100mm(3.94 inch) away from the main circuit and/or power cables. It may cause malfunction due to noise interference.

[INSTALLATION PRECAUTIONS]

CAUTION
<ul style="list-style-type: none"> ● Do not directly touch the module's conductive parts. Doing so could cause malfunction or trouble in the module. ● Tighten the module securely using DIN rail or installation screws within the specified torque range. Loose terminal screws may cause a short circuit or erroneous operation. If the terminal screws are too tight, it may cause falling, short circuit or erroneous operation due to damage of the screws.

[WIRING PRECAUTIONS]

DANGER
<ul style="list-style-type: none"> ● Completely turn off the externally supplied power used in the system when installing or placing wiring. Not completely turning off all power could result in electric shock or damage to the product.

CAUTION
<ul style="list-style-type: none"> ● Be sure to ground the FG terminals to the protective ground conductor. Not doing so could result in electric shock or erroneous operation. ● When wiring in the PLC, be sure that it is done correctly by checking the product's rated voltage and the terminal layout. ● Fix the attachment screws of waterproof cap and communication adapter securely within the specified torque range. Loose attachment screws may cause a fire or erroneous operation. If the attachment screws are too tight, it may cause a short circuit or erroneous operation due to damage of the screws. ● Make sure that foreign objects do not get in side the module, such as dirt and wire chips. It may cause fire product failure or malfunction. ● IP67 is only satisfied when the waterproof plug, waterproof cap, and communication adapter are all connected. ● Do not attach the communication cable to the I/O connector, as the I/O connector, the communication connector and the power supply connector are the same in shape. Failure to do so may cause frailer or malfunction of the PLC. ● Be sure to fix the wires or cables by ducts or clamps when connecting them to the module. Failure to do so may cause damage of the module or the cables due to accidental pull or unintentional shifting of the cables, or malfunctions due to poor contact of the cable. ● Do not install the control lines together with the communication cables, or bring them close to each other. Failure to do so may cause malfunctions due to noise.

[WIRING PRECAUTIONS]

CAUTION
<ul style="list-style-type: none"> ● When disconnecting a communication or power supply cable from the module, do not pull on the cable itself. Disconnect cables not fitted with a connectors by holding and pulling the cable connector. Disconnect cables not fitted with a connector by removing the screws from the part connected to the module can cause damage to the module or cable, or, malfunction due to cable connection faults.

[STARTING AND MAINTENANCE PRECAUTIONS]

DANGER
<ul style="list-style-type: none"> ● Do not touch terminals when the power is on. Doing so could cause an electric shock. ● Switch off all phases of the externally supplied power used in the system when cleaning the module or retightening the terminal or module mounting screws. Not doing so could result in electric shock.

CAUTION
<ul style="list-style-type: none"> ● Never try to disassemble of modify module. It may cause product failure, malfunction, fire or cause injury. ● Do not drop or apply any strong impact to the module. Doing so may damage the module. ● Completely turn off the externally supplied power used in the system before mounting or removing the module to/from the panel. Not doing so could result in damage to the product. ● Always make sure to touch the grounded metal to discharge the electricity charged in the electricity charged in the body, etc., before touching the module. Failure to do say cause a failure or malfunctions of the module.

[DISPOSAL PRECAUTIONS]

CAUTION
<ul style="list-style-type: none"> ● When disposing of this product, treat it as industrial waste.

(0706)MEE

1. Specification

	Item	Description
Input	Number of input points	8 points
	Isolation method	Photocoupler
	Rated input voltage	24 V DC
	Rated input current	Approx. 7 mA
	Operating voltage range	20.4 to 26.4 V DC (ripple ratio: within 5 %)
	Max. simultaneous ON input points	100 %
	ON voltage/ON current	14 V or higher/3.5 mA or higher
	OFF voltage/OFF current	6 V or lower/1.7 mA or lower
	Input resistance	Approx. 3.3 kΩ
	Response time	OFF→ON: 1.5 ms or lower (when 24 V DC) ON→OFF: 1.5 ms or lower (when 24 V DC)
Input form	Negative common (source type)	
Output	Number of output points	8 points
	Isolation method	Photocoupler
	Rated load voltage	24 V DC
	Operating load voltage range	20.4 to 26.4 V DC (ripple ratio: within 5 %)
	Max. load current	1.0 A/point 4.0 A/common
	Max. load inrush current	2.0 A 10 ms or lower
	Leakage current at OFF	0.3 mA or lower
	Max. voltage drop at ON	0.15 V or lower (TYP.) 1.0 A, 0.2 V or lower (MAX.) 1.0 A
	Response time	OFF→ON: 0.5 ms or lower ON→OFF: 1.5 ms or lower (resistive load)
	Output form	Source type
Protection function	Overload protection function, overheat protection function LED lights up when protection is occurring.	
External power supply for output part	Voltage	20.4 to 26.4 V DC (ripple ratio: within 5 %)
	Current	15 mA or lower (when 24 V DC, all points ON) Not including external load current
Surge suppressor	Zener diode	
Wiring method for common	16 points/common (waterproof connector 2 to 4-wire type: input, waterproof connector 2-wire type: output)	
Number of stations occupied	1 station 32 points assignment (use 16 points)	
I/O module power supply	Voltage	20.4 to 26.4 V DC (ripple ratio: within 5 %)
	Current	45 mA or lower (when 24 V DC, all points ON)
Noise durability	DC type noise voltage 500 Vp-p, noise width 1 μs, noise frequency 25 to 60 Hz (noise simulator condition)	
Withstand voltage	500 V AC for 1 minute between all DC external terminals and ground	
Insulation resistance	10 MΩ or higher, measured with a 500 V DC insulation resistance tester between all DC external terminals and ground	
Protection of degree	IP67	
Weight	0.40 kg	
Option	Waterproof cap: A6CAP-WP2	

For information about the connection devices necessary to use the main module, see the CC-Link System Small-Type Remote I/O Module User's Manual.

Printed in Japan on recycled paper.

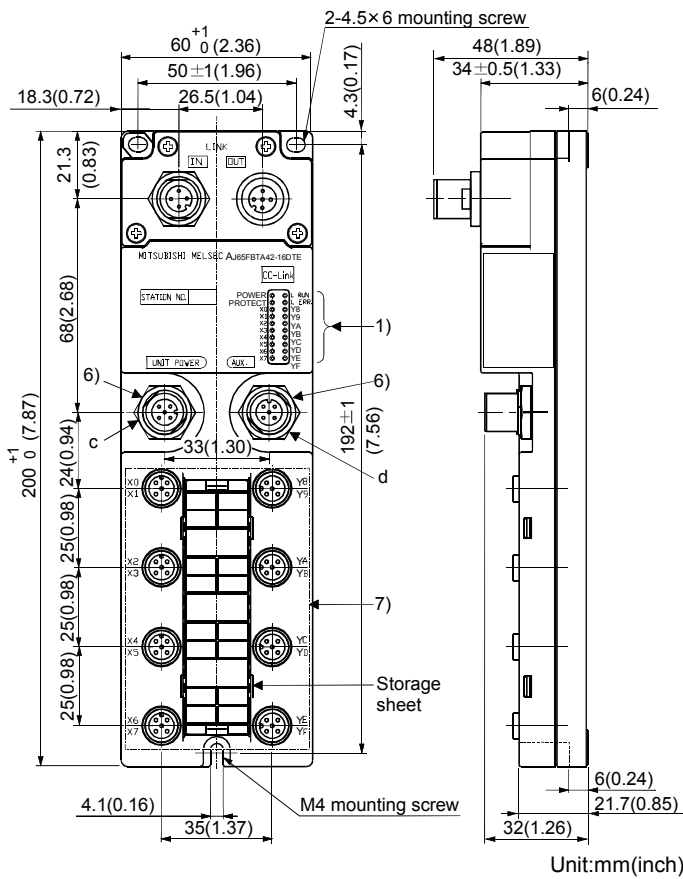

Unit:mm(inch)

Connector for connection to main module

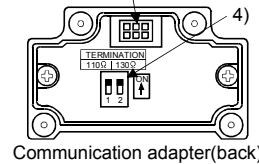

Communication adapter(back)

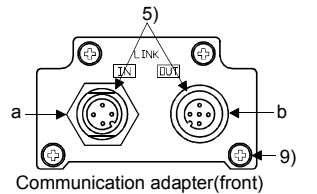

Communication adapter(front)

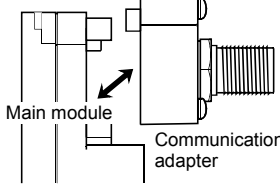

Main module
Communication adapter

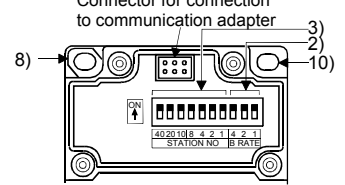

2. Name and Setting of Each Area

No.	Item	Description																																			
1)	Operating status indicator LEDs	<table border="1"> <thead> <tr> <th>LED name</th> <th>Confirmation details</th> </tr> </thead> <tbody> <tr> <td>POWER</td> <td>ON: Power supply ON OFF: Power supply OFF</td> </tr> <tr> <td>PROTECT</td> <td>Lights up when the output section protection function is working (During the protect operation, fuse interruption is searched in the master unit side)</td> </tr> <tr> <td>L RUN</td> <td>ON: Normal communication OFF: Communication shut off (time expiration error)</td> </tr> <tr> <td>L ERR.</td> <td>ON: Communication data error Flash at regular intervals: Indicates that the station number setting or transmission speed setting switch position was changed while power is ON Flash at irregular intervals: When the setting of the terminal resistor is wrong; when the cable for the module or CC-Link is affected by noise OFF: Normal communication</td> </tr> <tr> <td>X0 to X7 Y8 to YF</td> <td>ON: Input/Output ON OFF: Input/Output OFF</td> </tr> </tbody> </table>	LED name	Confirmation details	POWER	ON: Power supply ON OFF: Power supply OFF	PROTECT	Lights up when the output section protection function is working (During the protect operation, fuse interruption is searched in the master unit side)	L RUN	ON: Normal communication OFF: Communication shut off (time expiration error)	L ERR.	ON: Communication data error Flash at regular intervals: Indicates that the station number setting or transmission speed setting switch position was changed while power is ON Flash at irregular intervals: When the setting of the terminal resistor is wrong; when the cable for the module or CC-Link is affected by noise OFF: Normal communication	X0 to X7 Y8 to YF	ON: Input/Output ON OFF: Input/Output OFF																							
		LED name	Confirmation details																																		
POWER	ON: Power supply ON OFF: Power supply OFF																																				
PROTECT	Lights up when the output section protection function is working (During the protect operation, fuse interruption is searched in the master unit side)																																				
L RUN	ON: Normal communication OFF: Communication shut off (time expiration error)																																				
L ERR.	ON: Communication data error Flash at regular intervals: Indicates that the station number setting or transmission speed setting switch position was changed while power is ON Flash at irregular intervals: When the setting of the terminal resistor is wrong; when the cable for the module or CC-Link is affected by noise OFF: Normal communication																																				
X0 to X7 Y8 to YF	ON: Input/Output ON OFF: Input/Output OFF																																				
2)	Transmission speed setting switch	<table border="1"> <thead> <tr> <th>Setting value</th> <th colspan="3">Setting switch status</th> <th>Transmission speed</th> </tr> <tr> <th></th> <th>4</th> <th>2</th> <th>1</th> <th></th> </tr> </thead> <tbody> <tr> <td>0</td> <td>OFF</td> <td>OFF</td> <td>OFF</td> <td>156 kbps</td> </tr> <tr> <td>1</td> <td>OFF</td> <td>OFF</td> <td>ON</td> <td>625 kbps</td> </tr> <tr> <td>2</td> <td>OFF</td> <td>ON</td> <td>OFF</td> <td>2.5 Mbps</td> </tr> <tr> <td>3</td> <td>OFF</td> <td>ON</td> <td>ON</td> <td>5.0 Mbps</td> </tr> <tr> <td>4</td> <td>ON</td> <td>OFF</td> <td>OFF</td> <td>10 Mbps</td> </tr> </tbody> </table> <p>Be sure to set the transmission speed within the above range. Remove the communication adapter on the top part of the module to set the transmission speed. (When shipped from the factory, all settings are set to OFF.)</p>	Setting value	Setting switch status			Transmission speed		4	2	1		0	OFF	OFF	OFF	156 kbps	1	OFF	OFF	ON	625 kbps	2	OFF	ON	OFF	2.5 Mbps	3	OFF	ON	ON	5.0 Mbps	4	ON	OFF	OFF	10 Mbps
		Setting value	Setting switch status			Transmission speed																															
	4	2	1																																		
0	OFF	OFF	OFF	156 kbps																																	
1	OFF	OFF	ON	625 kbps																																	
2	OFF	ON	OFF	2.5 Mbps																																	
3	OFF	ON	ON	5.0 Mbps																																	
4	ON	OFF	OFF	10 Mbps																																	
3)	Station number setting switch	<p>Select "10", "20" or "40" to set the tens place of the station number. Select "1", "2", "4" or "8" to set the ones place of the station number. Always set the station number within the range of 1 to 64. (*1) (Example) Set the switches as below when setting the station number to 32:</p> <table border="1"> <thead> <tr> <th rowspan="2">Station number</th> <th colspan="2">Tens place</th> <th colspan="2">Ones place</th> </tr> <tr> <th>40</th> <th>20</th> <th>10</th> <th>8</th> <th>4</th> <th>2</th> <th>1</th> </tr> </thead> <tbody> <tr> <td>32</td> <td>OFF</td> <td>ON</td> <td>ON</td> <td>OFF</td> <td>OFF</td> <td>ON</td> <td>OFF</td> </tr> </tbody> </table> <p>Remove the communication adapter on the top part of the module to set the station number. (When shipped from the factory, all settings are set to OFF.)</p>	Station number	Tens place		Ones place		40	20	10	8	4	2	1	32	OFF	ON	ON	OFF	OFF	ON	OFF															
		Station number		Tens place		Ones place																															
40	20		10	8	4	2	1																														
32	OFF	ON	ON	OFF	OFF	ON	OFF																														
4)	Terminal resistance setting switch	<p>The terminal resistor can be turned to the ON setting by using the select switch.</p> <table border="1"> <thead> <tr> <th>DIP switch1</th> <th>DIP switch2</th> <th>Contents</th> </tr> </thead> <tbody> <tr> <td>OFF</td> <td>OFF</td> <td>No terminal resistance</td> </tr> <tr> <td>ON</td> <td>OFF</td> <td>110Ω resistor ON</td> </tr> <tr> <td>OFF</td> <td>ON</td> <td>130Ω resistor ON</td> </tr> <tr> <td>ON</td> <td>ON</td> <td>Setting prohibited</td> </tr> </tbody> </table> <p>(When shipped from the factory, all settings are set to OFF.)</p>	DIP switch1	DIP switch2	Contents	OFF	OFF	No terminal resistance	ON	OFF	110Ω resistor ON	OFF	ON	130Ω resistor ON	ON	ON	Setting prohibited																				
		DIP switch1	DIP switch2	Contents																																	
OFF	OFF	No terminal resistance																																			
ON	OFF	110Ω resistor ON																																			
OFF	ON	130Ω resistor ON																																			
ON	ON	Setting prohibited																																			
5)	Waterproof connector for transmission line *2	<table border="1"> <thead> <tr> <th>Silk</th> <th>Contents</th> </tr> </thead> <tbody> <tr> <td>a LINK IN</td> <td>Connector for connecting the transmission line from the IN side (master station side). (Male 4 pins)</td> </tr> <tr> <td>b LINK OUT</td> <td>Connector for connecting the transmission line from the OUT side. Be sure to attach the waterproof cap when not in use. (Female 5 pins) (Tightening torque range: 29 to 34 N.cm)</td> </tr> </tbody> </table>	Silk	Contents	a LINK IN	Connector for connecting the transmission line from the IN side (master station side). (Male 4 pins)	b LINK OUT	Connector for connecting the transmission line from the OUT side. Be sure to attach the waterproof cap when not in use. (Female 5 pins) (Tightening torque range: 29 to 34 N.cm)																													
		Silk	Contents																																		
a LINK IN	Connector for connecting the transmission line from the IN side (master station side). (Male 4 pins)																																				
b LINK OUT	Connector for connecting the transmission line from the OUT side. Be sure to attach the waterproof cap when not in use. (Female 5 pins) (Tightening torque range: 29 to 34 N.cm)																																				
6)	Waterproof connector for power line *2	<table border="1"> <thead> <tr> <th>Silk</th> <th>Contents</th> </tr> </thead> <tbody> <tr> <td>c UNIT POWER</td> <td>Connector for supplying power to the module. (Male 5 pins)</td> </tr> <tr> <td>d AUX.</td> <td>Connector for supplying power to a load, etc. (Male 5 pins)</td> </tr> </tbody> </table>	Silk	Contents	c UNIT POWER	Connector for supplying power to the module. (Male 5 pins)	d AUX.	Connector for supplying power to a load, etc. (Male 5 pins)																													
		Silk	Contents																																		
c UNIT POWER	Connector for supplying power to the module. (Male 5 pins)																																				
d AUX.	Connector for supplying power to a load, etc. (Male 5 pins)																																				
7)	Waterproof connector for input connection *2	Waterproof connector for connection I/O signal. (Female 5 pins) Be sure to attach waterproof cap A6CAP-WP2 (sold separately) when not in use. (Tightening torque range: 29 to 34 N.cm)																																			
8)	FG metal fitting	For module FG terminal (tightening torque range: 78 to 118 N.cm)																																			
9)	Communication adapter fixing screw	When replacing the main body online or changing switch setting, attach/remove the communication adapter with this screw. (Tightening torque range: 42 to 58 N.cm)																																			
10)	Module attachment hole	Screw hole for module attachment. 2-4.5 X 6 length hole (M4 attachment screw) (Tightening torque range: 78 to 118 N.cm)																																			

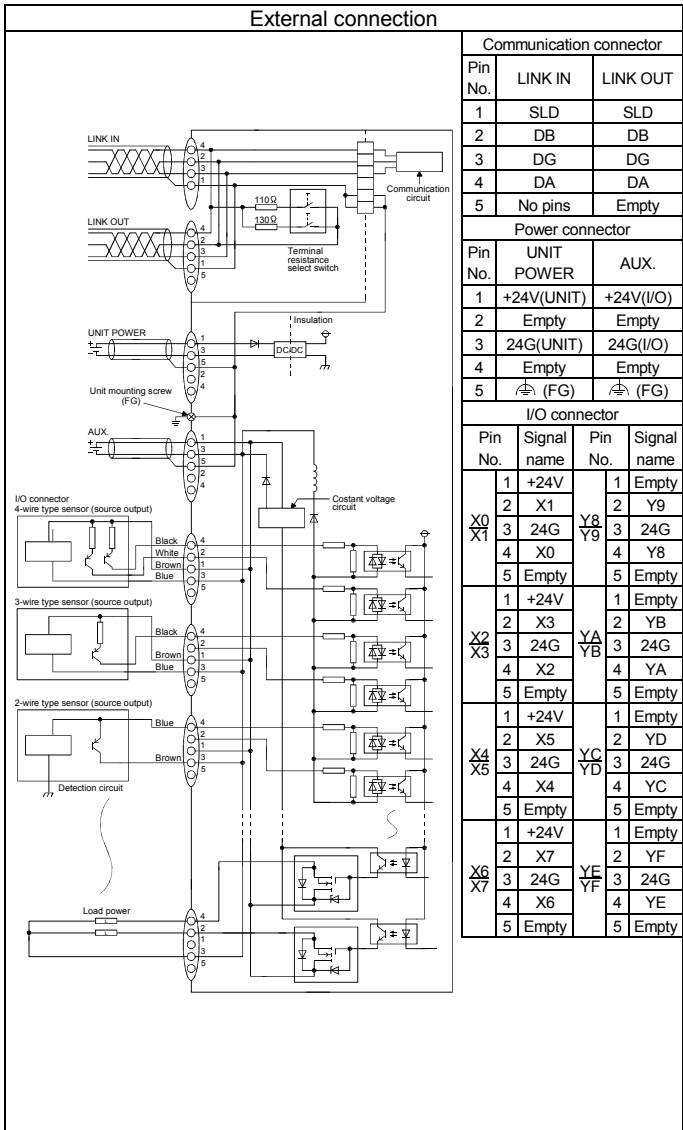

*1: Duplicate station number cannot be set.

*2: Waterproof connector (based on IEC947-5-2, M12 type)