

# GC4000 Series Installation Guide

10/2011

English

简体中文

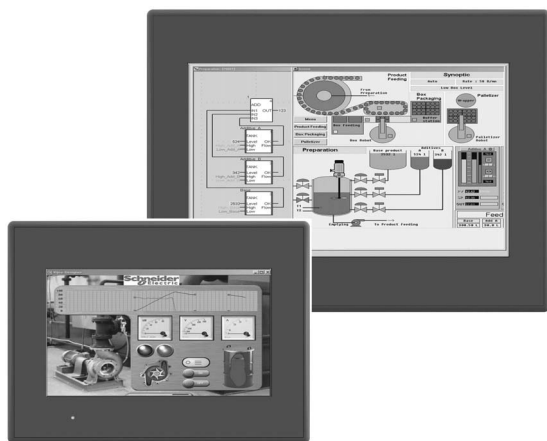



# Important Information

## NOTICE

Read these instructions carefully, and look at the equipment to become familiar with the device before trying to install, operate, or maintain it. The following special messages may appear throughout this documentation or on the equipment to warn of potential hazards or to call attention to information that clarifies or simplifies a procedure.



The addition of this symbol to a Danger safety label indicates that an electrical hazard exists, which will result in personal injury if the instructions are not followed.



This is the safety alert symbol. It is used to alert you to potential personal injury hazards. Obey all safety messages that follow this symbol to avoid possible injury or death.

### **DANGER**

**DANGER** indicates an imminently hazardous situation which, if not avoided, **will result in** death or serious injury.

### **WARNING**

**WARNING** indicates a potentially hazardous situation which, if not avoided, **can result in** death or serious injury.

### **CAUTION**

**CAUTION** indicates a potentially hazardous situation which, if not avoided, **can result in** minor or moderate injury.

### **NOTICE**

**NOTICE** is used to address practices not related to physical injury.

## PLEASE NOTE

Electrical equipment should be installed, operated, serviced, and maintained only by qualified personnel. No responsibility is assumed by Pro-face for any consequences arising out of the use of this material.

A qualified person is one who has skills and knowledge related to the construction and operation of electrical equipment and its installation, and has received safety training to recognize and avoid the hazards involved.

suke Pro!" at <http://www.pro-face.com/otasuke/>.

## Product Related Information

### **DANGER**

#### **HAZARD OF ELECTRIC SHOCK, EXPLOSION OR ARC FLASH**

- Disconnect all power from all equipment including connected devices prior to removing any covers or doors, or installing or removing any accessories, hardware, cables, or wires except under the specific conditions specified in the appropriate hardware guide for this equipment.
- Always use a properly rated voltage sensing device to confirm the power is off.
- Unplug the power cable from both the equipment and the power supply.
- Replace and secure all covers, accessories, hardware, cables, and wires and confirm that a proper ground connection exists before applying power to the equipment.
- Use only the specified voltage when operating this equipment and any associated products.

**Failure to follow these instructions will result in death or serious injury.**

## **WARNING**

### **LOSS OF CONTROL**

- Consider the potential failure modes of control paths in the machine control system design, such as:
  - The possibility of backlight failure,
  - Unanticipated link transmission delays or failures,
  - The operator being unable to control the machine,
  - The operator making errors in the control of the machine.
- Provide a means to achieve a safe state during and after a path failure for critical control functions such as emergency stop and overtravel stop.
- Provide separate or redundant control paths for critical control functions.
- Test individually and thoroughly each implementation of the panel for correct operation before service.

**Failure to follow these instructions can result in death, serious injury, or equipment damage.**



# GC4000 Series of Panels

## GC4000 Part Numbers

The following table presents the different GC4000 panels:

| Part number | Screen size         | USB type A | USB type mini B | RS232            | RS422/RS485      | RTC battery |
|-------------|---------------------|------------|-----------------|------------------|------------------|-------------|
| GC4408W     | 17.78 cm (7 in.)    | No         | Yes             | Yes <sup>1</sup> | Yes <sup>1</sup> | No          |
| GC4401W     | 17.78 cm (7 in.)    | Yes        | Yes             | Yes              | Yes              | Yes         |
| GC4501W     | 25.65 cm (10.1 in.) | Yes        | Yes             | Yes              | Yes              | Yes         |

<sup>1</sup> If "COM1" (RS232) is selected, COM2 (RS422/RS485) cannot be used. If "COM2" (RS422/RS485) is selected, COM1 (RS232) cannot be used.

## Package Contents

Make sure all items listed here are included in the panel package.:

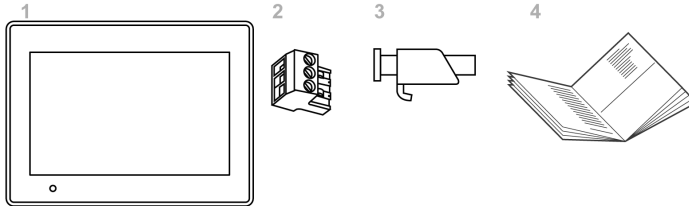

- 1 Panel
- 2 DC power connector
- 3 Screw installation fasteners (GC4408W and GC4401W: x4, GC4501W: x6)
- 4 GC4000 Installation guide

## Handling the LCD panel

### CAUTION

#### SERIOUS EYE AND SKIN INJURY

The LCD panel's liquid contains an irritant. Avoid direct skin contact with the liquid.

- Wear gloves when you handle a broken or leaking panel.
- Do not use sharp objects or tools in the vicinity of the LCD touch panel.
- Handle the LCD panel carefully to prevent puncture, bursting, or cracking of the panel material.



**Failure to follow these instructions can result in injury or equipment damage.**

If the panel is damaged and any liquid comes in contact with your skin, immediately rinse the area with running water for at least 15 minutes. If the liquid gets in your eyes, immediately rinse your eyes with running water for at least 15 minutes and consult a doctor.

## Product Label Sticker

You can identify the product version (PV) and the revision level (RL) from the product label on the panel.

The following diagram is a representation of a typical label:

|  |  |   |
|--|--|---|
| <b>Pro-face</b><br><small>DIGITAL ELECTRONICS CORP. JAPAN</small>  |  |   |
| <small>GC-4401W</small><br><small>MODEL: PFXGE4401WAD</small><br><small>RATING: 24VDC, 8.7W max, Class 2</small><br><small>SN: WXS1B274171101100011</small><br><small>PV: XX RL: XX SV: XX</small> | <small>DATE: 05/11</small><br><small>Made in China</small> | <small>Max. ambient temp. 50°C</small>  |
| <small>REV A B C D E F G H I J K L M N O P Q R S T U V W X Y Z 1 2 3 4 5</small>   |  |   |
|   |  |   |

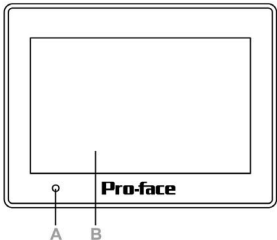
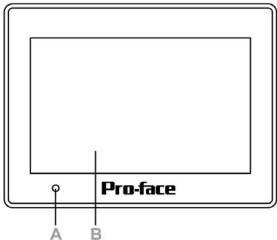
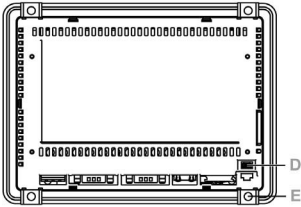
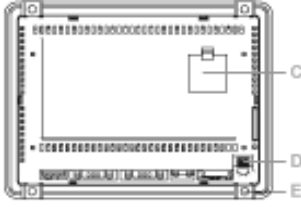
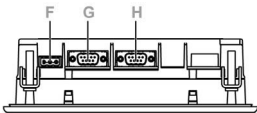
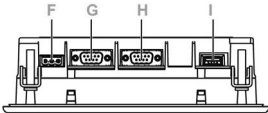

## GC4000 Parts Identification

| Side   | GC4408W   | GC4-01W   |
|--------|---|---|
| Front  |  |  |
| Rear   |  |  |
| Bottom |  |  |

| Part | Description   |
|------|---|
| A    | LED Indicator   |
| B    | Touch panel   |
| C    | Replaceable battery for RTC   |
| D    | USB (Type mini B)   |
| E    | Screw installation fasteners (GC4408W and GC4401W: x4, GC4501W: x6) |
| F    | Power connector   |
| G    | Serial Interface COM1 (RS232)                                       |
| H    | Serial Interface COM2 (RS485/RS422)                                 |
| I    | USB (Type A)  |

# Installation

## Panel-cut

Create a panel-cut and insert the panel from the front. The following illustration shows the panel-cut for the GC4000 series:

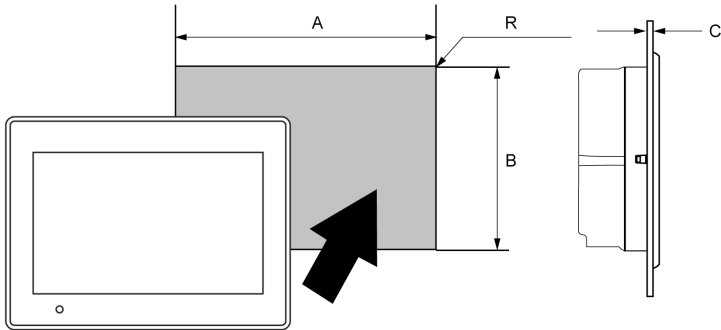

## Panel-cut Dimensions

The following table shows the panel-cut dimensions for each panel:

| Model   | A                                       | B   | C (Panel Thickness)             | R                         |
|---------|---|---|---------------------------------|---------------------------|
| GC440•W | 190 mm (7.48 in)<br>± 1 mm (0.04 in)    | 135 mm (5.31 in)<br>±0.7 mm (0.03 in)         | 1.5...10 mm<br>(0.06...0.39 in) | 3 mm<br>(0.12 in)<br>max. |
| GC4501W | 255 mm (10.04 in)<br>± 1.8 mm (0.07 in) | 185 mm (7.28 in)<br>+1 mm (0.04 in) -<br>0 mm | 1.5...10 mm<br>(0.06...0.39 in) | 3 mm<br>(0.12 in)<br>max. |

## Installation Fasteners

Mount the panel in an enclosure that provides a clean, dry, robust and controlled environment (IP65 enclosure) (*see GC4000 Series Hardware Manual, ).*

The fasteners are used to mount the GC4000 series:

| Model   | Screw Installation Fasteners |
|---------|------------------------------|
| GC440•W | 4                            |
| GC4501W | 6                            |

## Panel Setup Procedure

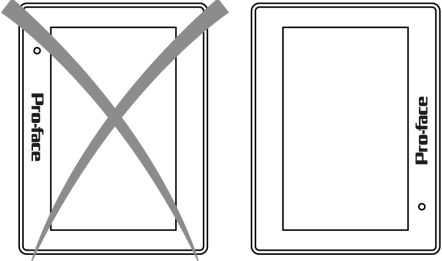
| Stage | Description   |
|-------|---|
| 1     | Check that the installation panel or the surface of the cabinet is flat, in good condition and has no jagged edges. Metal reinforcing strips may be attached to the inside of the panel wall, near the panel-cut, to increase the rigidity of the panel.      |
| 2     | Decide on the installation the thickness of the panel based on the level of panel strength required: 1.5 mm (0.06 in.) to 10 mm (0.4 in.).  |
| 3     | Be sure that the ambient operation temperature and the ambient humidity are within their designated ranges. (When installing the panel in a cabinet or enclosure, the ambient operation temperature is the internal temperature of the cabinet or enclosure.) |
| 4     | Be sure that heat from surrounding equipment does not cause the panel to exceed its standard operating temperature ( <i>see GC4000 Series Hardware Manual, .</i> )  |
| 5     | When installing the panel in a vertical position, the logo on the panel face must be on the right side to keep the power connector at the top.<br>                           |

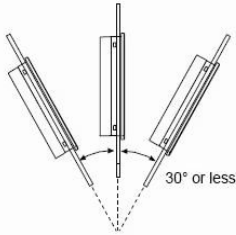
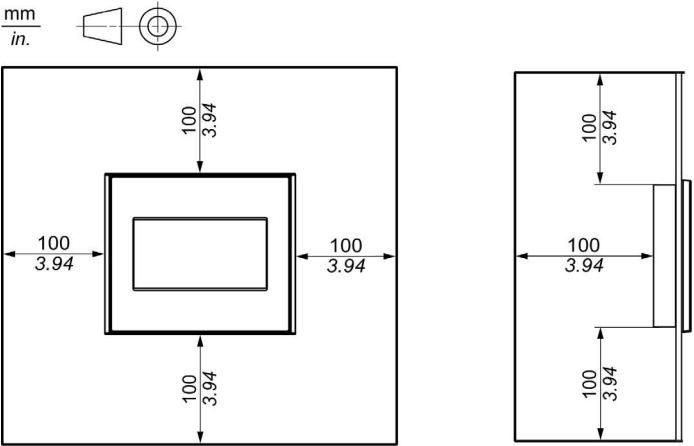
| Stage | Description  |
|-------|--|
| 6     | <p>When installing the panel in a slanted position, the panel face should not incline more than 30°.</p>  <p>When installing the panel in a slanted position, and the panel face inclines more than 30°, the ambient temperature must not exceed 40 °C. You may need to use forced air cooling (fan, A/C) to ensure the ambient operating temperature is 40°C or below.</p> |
| 7     | <p>For easier maintenance, operation and improved ventilation, install the panel at least 100 mm (3.94 in.) away from adjacent structures and other equipment as shown in the following illustration:</p>  <p>mm<br/>in.</p>   |

### Panel Mounting Procedure

|  |
|--|
| <h2><b>NOTICE</b></h2>   |
| <b>PANEL UNSTEADY WHEN UNSECURED</b>   |
| Keep panel stabilized in the panel-cut while you are installing or removing the screw fasteners. |
| <b>Failure to follow these instructions can result in equipment damage.</b>                      |

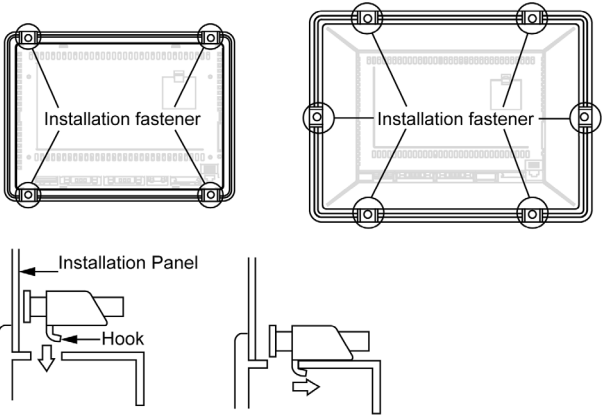
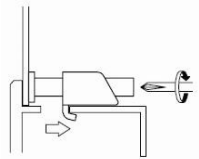
| Step | Action  |
|------|---|
| 1    | Place the panel on a clean and level surface with the display face pointing downward.   |
| 2    | Check that the gasket of the panel is seated securely which runs around the perimeter of the frame.   |
| 3    | Create the correct sized opening required to install the panel, using the installation dimensions (see <i>GC4000 Series Hardware Manual</i> , ).  |
| 4    | Insert the panel into the panel-cut.  |
| 5    | <p>Insert the installation fasteners into the panel's insertion slots on the top and bottom sides (and left and right sides for the GC4501W). Slide the fasteners flat against the panel. If the fasteners are not correctly attached, the panel may shift or fall out.</p>  |
| 6    | <p>Use a Phillips screwdriver to tighten each fastener and secure the panel in place. The necessary torque is 0.8...1 Nm (7.08...8.85 lb-in):</p>    |

## NOTICE

### BROKEN ENCLOSURE

Do not exert more than 1 Nm (8.85 in-lb) of torque when tightening the fastener's screws.

**Failure to follow these instructions can result in equipment damage.**

## Installing and Replacing the RTC Battery

While lithium batteries are preferred due to their slow discharge and long life, they can present hazards to personnel, equipment and the environment, and must be handled properly.

### ⚠ DANGER

**EXPLOSION, FIRE, OR CHEMICAL HAZARD**

Follow these instructions for the lithium batteries:

- Replace with identical type.
- Follow all battery manufacturer's instructions.
- Remove all replaceable batteries before discarding panel.
- Recycle or properly dispose of used batteries.
- Protect battery from any potential short circuit.
- Do not recharge, disassemble, heat above 100 °C (212 °F), or incinerate.
- Use your hands or insulated tools to remove or replace the battery.
- Maintain proper polarity when inserting and connecting a new battery.

**Failure to follow these instructions will result in death or serious injury.**

**NOTE:** Replace battery only with identical type: Renata Type CR2032.

To install or replace the RTC battery, follow these steps:

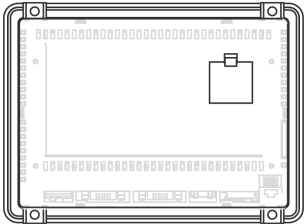
| Step | Action  |
|------|---|
| 1    | Power off your panel.   |
| 2    | Open the cover to access the backup battery compartment as shown below:   |
|      |                                        |
| 3    | Remove the used battery from the compartment.   |
| 4    | Insert the new battery in the compartment in accordance with the polarity markings in the compartment and on the battery. |
| 5    | Close the cover and verify that the latch clicks into place.  |

---

| Step | Action   |
|------|--|
| 6    | Power up your GC4000.<br><b>NOTE:</b> If you do not power up your GC4000 immediately, the external backup battery life may be significantly reduced.     |
| 7    | Set the internal clock. For further details on the internal clock, please refer to Adjusting the clock on the display (see the GP-Pro EX screen editor). |

**NOTE:** Replacement of the panel's battery other than with the type specified in this documentation may present a risk of fire or explosion.

# Wiring Principles

## Connecting the Power Cord

Follow these instructions when supplying power to the panel:

- When the functional ground (FG) terminal is connected, be sure the wire is grounded. Not grounding the panel can result in excessive Electromagnetic Interference (EMI). Grounding is required to meet EMC level immunity.
- The shield ground (SG) and FG terminals are connected internally in the panel.
- Disconnect the power before wiring the panel's power terminals.
- The panel uses only 24 Vdc power. Using any other level of power can damage both the power supply and the panel.
- Since the panel is not equipped with a power switch, be sure to connect a power switch to the panel's power supply.
- Be sure to ground the panel's FG terminal.

## Power Cord Preparation

- Make sure the ground wire is either the same or heavier gauge than the power wires.
- Do not use aluminum wires in the power supply's power cord.
- If the ends of the individual wires are not twisted correctly, the wires may create a short circuit. To avoid this, use D25CE/AZ5CE cable ends.
- Wherever possible, use wires that are 0.75 to 2.5 mm<sup>2</sup> (AWG 18 - 12) for the power cord, and twist the wire ends before attaching the terminals.
- The conductor type is solid or stranded wire.

## Power Plug Illustration

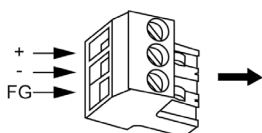

| Connection | Wire  |
|------------|---|
| +          | 24 Vdc  |
| -          | 0 Vdc   |
| FG         | Grounded terminal connected to the panel chassis. |



## How to Connect the Power Cord

The following table explains how to connect the power plug:

| Step | Action   |
|------|--|
| 1    | Remove the power cord from the power supply.   |
| 2    | Remove the power plug from the panel.  |
| 3    | Remove 7 mm (0.28 in.) of the vinyl cover off the ends of the power cord wires.  |
| 4    | If using stranded wire, twist the ends. Tinning the ends with solder reduces risk of fraying and ensures good electrical transfer. |
| 5    | Connect the wires to the power plug by using a flat-bladed screwdriver (size 0.6 X 3.5).   |
| 6    | Tighten the mounting screws using the defined torque: 0.5...0.6 nm (5...7 lb-in).  |
| 7    | Replace the power plug onto the power connector.   |

### NOTE:

- Do not solder the wire directly to the power receptacle pin.
- The power supply cord should meet the specification shown above. Be sure to twist the power cords together, up to the power plug, for EMC cancellation.

## Connecting the Power Supply

- Connect the power cord to the power connector on the side of the panel using the power plug.
- Between the line and the ground, be sure to use a regulated power supply with a Class 2 power supply.
- To increase the electromagnetic noise resistance, be sure to twist the ends of the power cord wires before connecting them to the power plug.
- The panel's power supply cord should not be bundled with or kept close to main circuit lines (high voltage, high current), or input/output signal lines.
- Connect a lightning surge absorber to handle power surges.
- To reduce electromagnetic noise, make the power cord as short as possible.

## ⚠ WARNING

### SHORT CIRCUITS, FIRE, OR UNINTENDED EQUIPMENT OPERATION

Avoid excessive force on the power cable to prevent accidental disconnection:

- Securely attach power cables to the panel or cabinet.
- Use the torque 0.8...1 Nm (7.08...8.85 in-lb) to tighten the panel's terminal block screws.
- Install and fasten panel on installation panel or cabinet prior to connecting Power Supply and Communication lines.

**Failure to follow these instructions can result in death, serious injury, or equipment damage.**

## Power Supply Connections

For ease of maintenance, use the following connection diagram to set up your power supply connections.

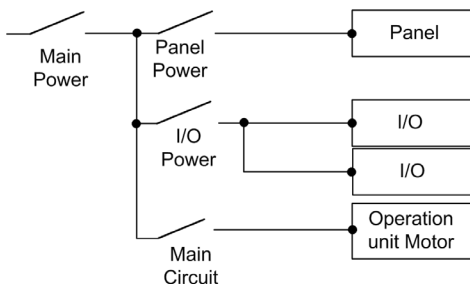

### NOTE:

- Ground the surge absorber (E1) separately from the panel (E2).
- Select a surge absorber that has a maximum circuit voltage greater than that of the peak voltage of the power supply.

The following shows a lightning surge absorber connection:

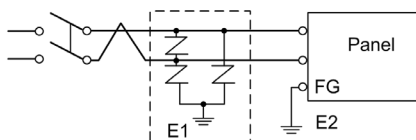

## Grounding

Take the following precautions for grounding the panel. Connect the functional ground (FG) terminal on the power plug to an exclusive ground.

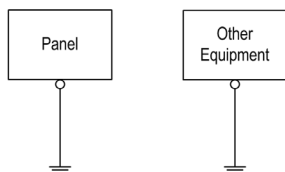

## Grounding Procedure

| Step   | Action  |
|--|---|
| 1  | Check that the grounding resistance is less than $0.1 \Omega$ <sup>(1)</sup> .  |
| 2  | The FG wire should have a cross sectional area greater than $2 \text{ mm}^2$ <sup>(1)</sup> . Create the connection point as close to the panel as possible, and make the wire as short as possible. When using a long grounding wire, replace the thin wire with a thicker wire, and place it in a duct. |
| 3  | If the equipment does not function properly when grounded, disconnect the ground wire from the FG terminal.   |
| <sup>(1)</sup> Observe local codes and standards. Ensure the ground connection has a resistance of less than $0.1 \Omega$ and that the ground wire has a cross-section of at least $2 \text{ mm}^2$ or AWG 14. |   |

## Common Grounding

Electromagnetic Interference (EMI) can be created if the devices are improperly grounded. EMI can cause loss of communication.

Do not use common grounding, except for the authorized configuration described below.

If exclusive grounding is not possible, use a common connection point.

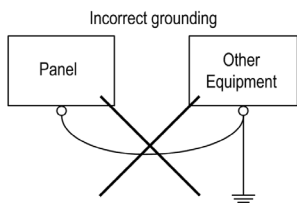
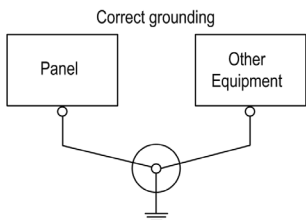

## USB Interface

### USB Holder

When using a USB device, attaching a USB holder to the USB interface on the side of the panel helps prevent the USB cable from being disconnected.

### **⚠ WARNING**

#### **RISK OF EXPLOSION IN HAZARDOUS LOCATIONS**

- Remove power before attaching or detaching any connector(s) to or from the equipment.
- Confirm that the USB cable has been attached with the USB holder before using the USB host interface.

**Failure to follow these instructions can result in death, serious injury, or equipment damage.**

### Attaching the USB Holder Type A

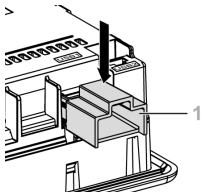
| Step | Action   |
|------|--|
| 1    | <p>Attach the USB holder to the USB Host Interface on the main panel. Hook the upper pick of the USB holder to the attachment hole of the main panel, and insert the lower pick as shown below to fix the USB holder.</p>  <p>1 USB holder</p> |

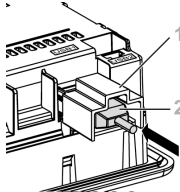
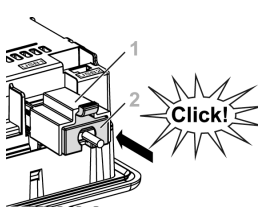
| Step | Action  |
|------|---|
| 2    | <p>Insert the USB cable into the USB host interface.</p>  <p>1 USB holder<br/>2 USB cable</p>  |
| 3    | <p>Attach the USB cover to fix the USB cable in place. Insert the USB cover into the tab of the USB holder.</p>  <p>1 USB holder<br/>2 USB cover</p> |

### Removing the USB Holder Type A

Lift up the tab of the USB holder and then remove the USB cover.

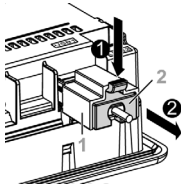

- 1 USB holder
- 2 USB cover

## Attaching the USB Holder Type mini B

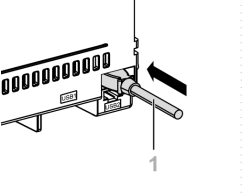
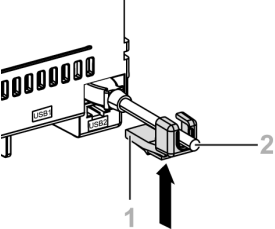
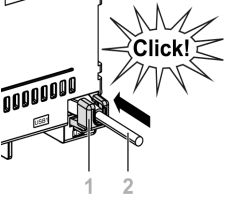
| Step | Action  |
|------|---|
| 1    | <p>Insert the USB cable into the USB host interface.</p>  <p>1 USB cable</p>                     |
| 2    | <p>Attach the USB holder to fix the USB cable in place.</p>  <p>1 USB holder<br/>2 USB cable</p> |
| 3    | <p>Insert the USB holder into the tab.</p>  <p>1 USB holder<br/>2 USB cable</p>                 |

---

## Removing the USB Holder Type mini B

Squeeze the tab of the USB holder and then remove the USB holder.

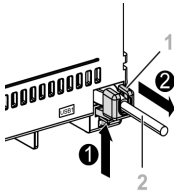

- 1 USB holder
- 2 USB cable



# GC4000

## 系列安装指南

简体中文

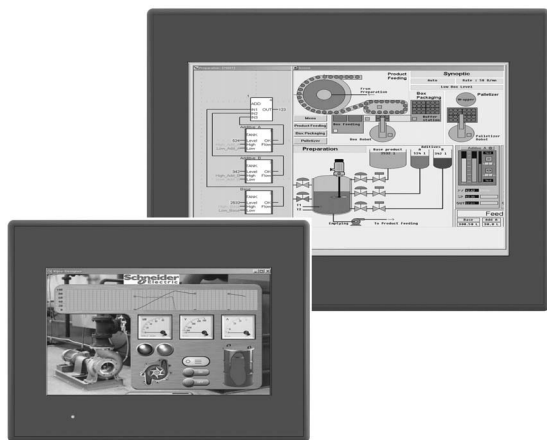



---

本文档中提供的信息包含有关此处所涉及产品之性能的一般说明和 / 或技术特性。本文档并非用于（也不代替）确定这些产品对于特定用户应用场合的适用性或可靠性。任何此类用户或集成者都有责任就相关特定应用场合或使用方面对产品执行适当且完整的风险分析、评估和测试。Pro-face 或是其任何附属机构或子公司都不对误用此处包含的信息而承担责任。如果您有关于改进或更正此出版物的任何建议，或者从中发现错误，请通知我们。

未经 Pro-face 明确书面许可，不得以任何形式、通过任何电子或机械手段（包括影印）复制本文档的任何部分。

在安装和使用本产品时，必须遵守国家、地区和当地的所有相关的安全法规。出于安全方面的考虑和为了帮助确保符合归档的系统数据，只允许制造商对各个组件进行维修。

当设备用于具有技术安全要求的应用场合时，必须遵守有关的使用说明。

如果在我们的硬件产品上不正确地使用 Pro-face 软件或认可的软件，则可能导致人身伤害、损害或不正确的操作结果。

不遵守此信息可能导致人身伤害或设备损坏。

© 2011 Digital Electronics Corporation。保留所有权利。

## 重要信息

### 声明

在尝试安装、操作或维护设备之前，请仔细阅读下述说明并通过查看来熟悉设备。下述特别信息可能会在本文其他地方或设备上出现，提示用户潜在的危險，或者提醒注意有关阐明或简化某一过程的信息。



在“危險”标签上添加此符号表示存在触电危險，如果不遵守使用说明，会导致人身伤害。



这是提醒注意安全的符号。提醒用户可能存在人身伤害的危險。请遵守所有带此符号的安全注意事项，以避免可能的人身伤害甚至死亡。

### 危險

“危險”表示极可能存在危險，如果不遵守说明，可导致严重的人身伤害甚至死亡。

### 警告

“警告”表示可能存在危險，如果不遵守说明，可导致严重的人身伤害甚至死亡，或设备损坏。

### 注意

“注意”表示可能存在危險，如果不遵守说明，可导致严重的人身伤害或设备损坏。

### 注意

“注意”用于表示与人身伤害无关的危害。

### 请注意

电气设备的安装、操作、维修和维护工作仅限于合格人员执行。对于使用本资料所引发的任何后果，Pro-face 概不负责。

专业人员是指掌握与电气设备的制造和操作及其安装相关的技能和知识的人员，他们经过安全培训能够发现和避免相关的危險。

## 危险

### 电击、爆炸或电弧危险

- 在卸除任何护盖或门，或安装或卸除任何附件、硬件、电缆或导线之前，先断开所有设备的电源连接（包括已连接设备），此设备的相应硬件指南中另有指定的特定情况除外。
- 始终使用合适的额定电压传感器确认所有电源已关闭。
- 从设备和电源上拔下电源线的插头。
- 更换并紧固所有护盖、附件、硬件、电缆与电线，并确认接地连接正确后再对设备通电。
- 在操作本设备及相关产品时，必须使用指定电压。

**如果不遵守这些说明，将会导致死亡或严重伤害。**

## 警告

### 失控

- 请谨慎考虑机器控制系统设计中控制路径的可能故障模式，例如：
  - 可能的背景灯故障，
  - 无法预料的链路传输延迟或故障，
  - 操作人员无法控制机器，
  - 操作人员在控制机器时操作错误。
- 为诸如紧急停止和超行程停止等关键控制功能发生路径故障期间或之后提供一个能达到安全状态的方法。
- 为关键控制功能提供单独或冗余的控制路径。
- 开始使用前，逐个彻底测试面板的每个实施以确认其能正常运行。

**如果不遵守这些说明，将会导致死亡、严重伤害或设备损坏。**

# GC4000 系列面板

## GC4000 部件号

下表列出了各种 GC4000 面板：

| 部件号     | 屏幕尺寸               | A 型 USB | mini B 型 USB | RS232          | RS422/<br>RS485 | RTC 电池 |
|---------|--------------------|---------|--------------|----------------|-----------------|--------|
| GC4408W | 17.78 cm (7 in)    | 否       | 是            | 有 <sup>1</sup> | 有 <sup>1</sup>  | 否      |
| GC4401W | 17.78 cm (7 in)    | 是       | 是            | 是              | 是               | 是      |
| GC4501W | 25.65 cm (10.1 in) | 是       | 是            | 是              | 是               | 是      |

<sup>1</sup> 如果选择 "COM1" (RS232)，则无法使用 COM2 (RS422/RS485)。如果选择 "COM2" (RS422/RS485)，则无法使用 COM1 (RS232)。

## 装箱物品

请确保您的面板包装中包含以下所有物品：

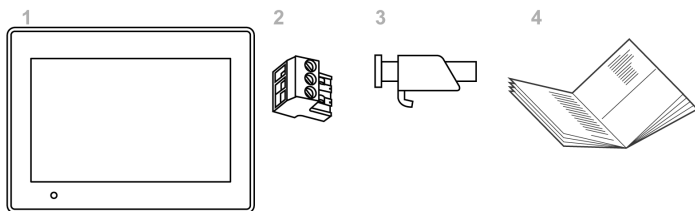

- 1 面板
- 2 直流电源连接器
- 3 螺钉安装扣件（GC4408W 和 GC4401W：x4，GC4501W：6 个）
- 4 GC4000 安装指南

## LCD 面板的使用事项



**小心**

### 严重的眼睛和皮肤伤害

LCD 屏的液体中含有刺激物。请避免皮肤直接接触此类液体。

- 在处理破损或易泄漏面板时，请戴上手套。
- 不要在 LCD 触摸屏附近使用尖锐的物体或工具。
- 接触 LCD 面板时要小心，避免导致面板材料被刺穿、爆裂或破裂。

**如果不遵守这些说明，将会导致受伤或设备损坏。**

如果面板损坏且您的皮肤接触到这类液体，请立即用流水冲洗接触部位至少 15 分钟。如果液体进入眼中，请立即用流水冲洗眼睛至少 15 分钟，然后上医院就医。

### 产品标签

您可从面板的产品标签上找到产品版本 (PV) 和修订级别 (RL)。

下图表示的是一个典型标签：

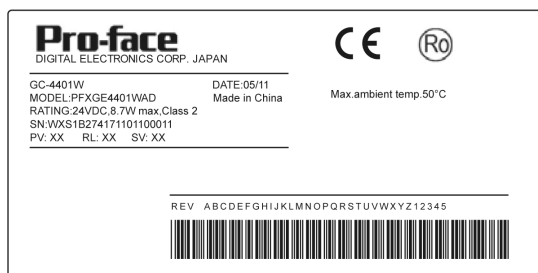

### GC4000 部件标识

|          | GC4408W | GC4•01W |
|----------|---------|---------|
| 侧面<br>正面 |         |         |
| 背面       |         |         |
| 底部       |         |         |

| 部件 | 说明   |
|----|--|
| A  | LED 指示灯                                      |
| B  | 触摸屏  |
| C  | 可更换 RTC 电池                                   |
| D  | USB (mini B 型)                               |
| E  | 螺钉安装扣件 (GC4408W 和 GC4401W: x4, GC4501W: 6 个) |
| F  | 电源接口   |
| G  | 串行接口 COM1 (RS232)                            |
| H  | 串行接口 COM2 (RS485/RS422)                      |
| I  | USB (A 型)                                    |



## 安装

### 面板开孔

开一个面板开孔并从前面插入面板。下图显示了 GC4000 系列的面板开孔：

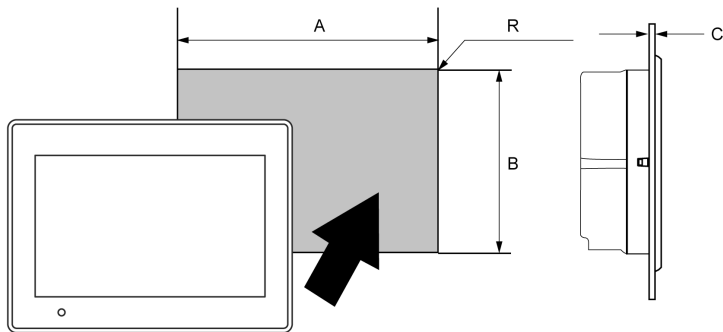

### 面板开孔尺寸

下表显示了各个面板的开孔尺寸：

| 型号      | A                                   | B                                     | C (面板厚度)                        | R                      |
|---------|-------------------------------------|---------------------------------------|---------------------------------|------------------------|
| GC440•W | 190mm (7.48in)<br>± 1mm (0.04in)    | 135mm (5.31in)<br>±0.7mm (0.03in)     | 1.5 到 10 mm<br>(0.06 到 0.39 in) | 3mm<br>(0.12 in)<br>最长 |
| GC4501W | 255mm (10.04in)<br>± 1.8mm (0.07in) | 185mm (7.28in)<br>+1mm (0.04in) - 0mm | 1.5 到 10 mm<br>(0.06 到 0.39 in) | 3mm<br>(0.12 in)<br>最长 |

### 安装扣件

将面板安装在提供干净、干燥、牢固和可控环境的机柜（IP65 机柜）（参见 *GC4000 系列硬件手册*，）中。

扣件用于安装 GC4000 系列：

| 型号      | 螺钉安装扣件 |
|---------|--------|
| GC440•W | 4      |
| GC4501W | 6      |

## 面板安装过程

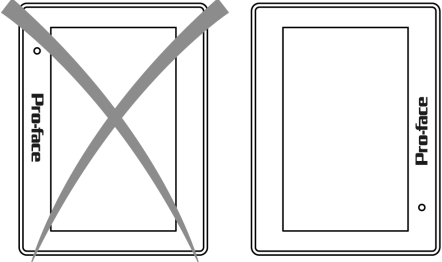
| 阶段 | 说明  |
|----|---|
| 1  | 检查安装面板或机柜表面是否平滑、状况良好且没有锯齿状边缘。可以在面板壁的内侧临近面板开孔处加上金属加固条以增强面板的稳固性。  |
| 2  | 根据所需的面板强度级别确定安装面板的厚度：1.5 mm (0.06 in.) 至 10 mm (0.4 in.)。   |
| 3  | 确保工作环境温度和湿度均在指定范围内。（在机柜或机箱中安装面板时，工作环境温度是指机柜或机箱的内部温度。）   |
| 4  | 请确保周围设备的散热不会导致本面板超出其标准工作温度（参见 <i>GC4000 系列硬件手册</i> ，）。  |
| 5  | 在垂直位置安装面板时，面板表面的标志必须位于右侧以使电源连接器位于顶部。<br> |

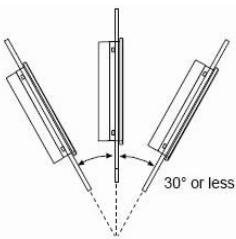
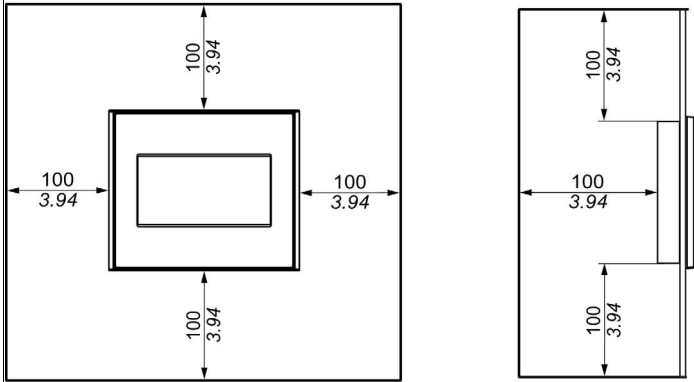
| 阶段 | 说明   |
|----|--|
| 6  | <p>在倾斜位置安装面板时，面板表面的倾斜度不得超过 30°。</p>  <p>在倾斜位置安装面板时，如果面板倾斜度超过了 30°，则环境温度不得超过 40 °C。您可以使用制冷设备（风扇、空调）来确保工作温度不超过 40 °C。</p> |
| 7  | <p>为了方便维护、操作及更好地通风，安装面板时请与相邻物体及其他设备间至少留出 100 mm (3.94 in) 的空隙，如下图所示：</p> <p>mm<br/>in.</p>                             |

### 面板安装步骤

## 注意

在未固定的情况下面板不稳定

在安装或取下螺钉扣件时，请确保面板在面板开孔中稳固。

如果不遵守这些说明，则会导致设备损坏。

| 步骤 | 操作                      |
|----|-------------------------|
| 1  | 将面板显示屏面朝下放置在干净的水平表面上。   |
| 2  | 检查确保面板的衬垫已牢固就位，围绕在框架周围。 |

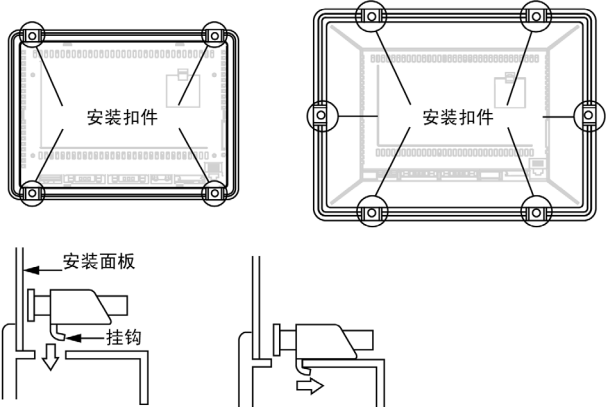
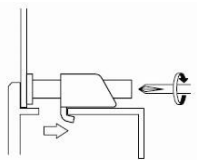
| 步骤 | 操作   |
|----|--|
| 3  | 根据安装尺寸 (参见 GC4000 系列硬件手册,) 开出大小合适的孔以安装面板。  |
| 4  | 将面板插入面板开孔。   |
| 5  | <p>将安装扣件插入面板顶侧和底侧 (以及 GC4501W 的左侧和右侧) 的插槽中。对着面板滑动扣件扁头。如果扣件安装不正确, 面板可能会移位或掉落。</p>  |
| 6  | <p>使用十字螺丝刀将每个扣件拧紧并将面板固定到位。需要 0.8 到 1Nm (7.08 到 8.85lb-in) 的力矩:</p>                |

## 注意

### 外围破裂

拧紧扣件的螺钉时, 施加的扭矩请勿超过 1Nm (8.85in-lb)。

**如果不遵守这些说明, 则会导致设备损坏。**

### 安装和更换 RTC 电池

锂电池由于其放电缓慢和较长的寿命而成为首选, 但它对操作人员、设备和环境会产生危害, 因此必须要妥善处理。

## ⚠ 危险

### 存在爆炸、火灾或化学危险

请遵循以下有关锂电池的使用说明：

- 请用同类电池进行更换。
- 请遵循电池生产商的所有使用说明。
- 丢弃面板之前，请卸除所有可更换的电池。
- 请循环利用或妥善处理用过的电池
- 防止电池发生任何可能的短路。
- 请勿将电池再充电、拆卸、加热至 100 °C (212 °F) 以上或焚烧。
- 请务必用手或绝缘工具卸除或更换电池。
- 在插入和连接新电池时，请注意极性的正确放置。

**如果不遵守这些说明，将会导致死亡或严重伤害。**

**注意：**请仅用同类电池进行更换：Renata 型 CR2032。

要安装或更换 RTC 电池，请按以下步骤操作：

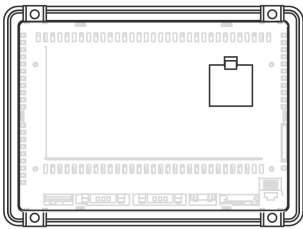
| 步骤 | 操作   |
|----|--|
| 1  | 关闭面板的电源。   |
| 2  | 打开备用电池舱的舱盖，如下图所示：  |
| 3  | 从电池舱中取出废旧旧电池。  |
| 4  | 按照电池舱中和电池上的电极标记在电池舱中插入新电池。   |
| 5  | 盖上电池舱盖并检查确认锁扣是否卡入到位。   |
| 6  | 打开 GC4000 的电源。<br><b>注意：</b> 如果不立即打开 GC4000 电源，外部备用电池的寿命有可能显著降低。                                     |
| 7  | 设置内部时钟。有关内部时钟的更多详细信息，请参阅调整显示屏上的时钟（参见 GP-Pro EX 屏幕编辑器）。   |

**注意：**更换的面板电池若不是本文档中指定的类型，可能会带来火灾或爆炸的风险。



## 接线规则

### 连接电源线

为面板供电时，请按以下说明操作：

- 当连接好功能接地 (FG) 端子后，确保将电线接地。如果不接地，面板将引起过大的电磁干扰。为了符合良好的电磁兼容性抗扰度，请务必接地。
- 屏蔽接地 (SG) 和 FG 端子在面板内部进行连接。
- 先断开电源，然后再为面板的电源端子接线。
- 面板仅使用 24 Vdc 直流电源。使用其他标准的电源可能会损坏电源和面板。
- 由于面板不带电源开关，因此务必先连接一个电源开关后再将电源连接到面板。
- 务必将面板的 FG 端子接地。

### 电源线准备

- 确保地线在规格上与电源线相同或比电源线重。
- 不要在电源线中使用铝线。
- 如果单根线的两端绞合不正确，则电线可能造成短路。为避免发生这种情况，请使用 D25CE/AZ5CE 电缆终端。
- 请尽可能使用 0.75 至 2.5 mm<sup>2</sup> (AWG 18 - 12) 规格的电线用作电源线，并且在连接到设备之前，请先把电缆末端绞合。
- 导线类型为实心或绞合型。

### 电源插头示意图

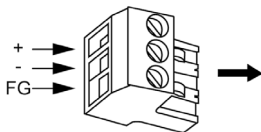

| 连接 | 导线            |
|----|---------------|
| +  | 24 Vdc        |
| -  | 0 Vdc         |
| FG | 连接到面板外壳的接地端子。 |

## 如何连接电源线

下表介绍了如何连接电源插头：

| 步骤 | 操作   |
|----|--|
| 1  | 从电源上拔下电源线。   |
| 2  | 从面板上拔下电源插头。  |
| 3  | 从电源线两端除去长 7 mm (0.28 in) 的塑料护套。                          |
| 4  | 如果使用的是双绞线，请将电缆末端绞合在一起。请给电缆末端焊锡，这样会减少电缆的磨损，并能保持良好的电流传输效果。 |
| 5  | 使用平头螺丝刀（尺寸 0.6 X 3.5）将电线接入电源插头中。                         |
| 6  | 以定义的扭矩拧紧安装螺钉：0.5 到 0.6 nm (5 到 7 lb-in)。                 |
| 7  | 将电源插头装回到电源连接器上。  |

### 注意：

- 请勿将导线直接焊接到电源插座的引脚上。
- 电源线应满足上述规格要求。确保将电源线一直绞合到电源插头处为止，以消除电磁干扰

### 连接电源

- 使用电源插头将电源线连接到面板侧面的电源连接器上。
- 确保使用 2 类电源在线路和地线间提供稳压电源。
- 要增加电磁耐受性能，请确保将电源线导线的末端绞合在一起，然后再接入电源插头中。
- 面板的电源线不得捆绑或距离主要电路线（高电压、高电流）或输入 / 输出信号线很近。
- 请连接雷电浪涌吸收器，吸收电源浪涌。
- 为减少电磁噪声，请使电源线尽量短。

## 警告

### 短路、火灾或意外的设备操作

避免因电源线过度拉紧而导致连接意外中断：

- 将电源线牢固地连接到面板或机柜。
- 使用力矩 0.8...1Nm (7.08...8.85in-lb) 紧固面板的端子块螺钉。
- 先将面板安装并固定到安装面板或机柜中，然后再连接电源和通讯线路。

**如果不遵守这些说明，将会导致死亡、严重伤害或设备损坏。**



## 电源连接

为了便于维护，请使用以下接线图来设置您的电源连接。

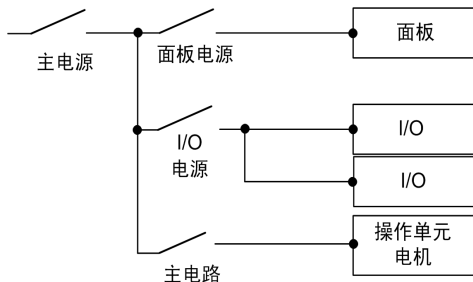

### 注意：

- 请将面板 (E2) 与电涌吸收器 (E1) 分别接地。
- 所选浪涌吸收器的最大电路电压应大于电源的峰值电压。

下图显示了雷电电涌吸收器的连接方法：

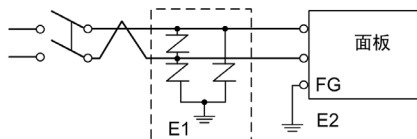

## 接地

将面板接地时请遵守以下安全注意事项。将电源插头上的功能接地 (FG) 端子连接到独立接地端。

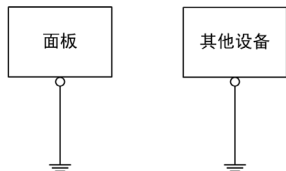

## 接地步骤

| 步骤 | 操作   |
|----|--|
| 1  | 请确保接地阻抗小于 $0.1 \Omega$ <sup>(1)</sup> 。  |
| 2  | 功能接地线的横截面积应大于 $2 \text{ mm}^2$ 。请确保连接点尽量靠近面板，导线尽可能短。当接地线较长时，请用粗线代替细线，并将导线插入电缆槽中。 |
| 3  | 如果接地后设备运行异常，请从 FG 端子上断开地线。   |

(1) 请遵守当地法规和标准。请确保地线连接中有一个小于  $0.1 \Omega$  的阻抗，且地线的横截面至少为  $2 \text{ mm}^2$  或 AWG 14。

## 公共接地

如果设备没有正确接地的话，将引起电磁干扰。电磁干扰有可能导致通讯丢失。

请勿使用公共接地端，除下述认可配置外。

如果无法连接到独立接地端，请使用公共连接点。

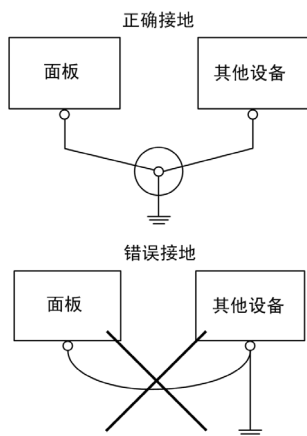

## USB 接口

### USB 固定架

使用 USB 设备时，可以将 USB 座连接到面板侧面的 USB 接口上，以防止 USB 电缆连接断开。

### 警告

#### 存在爆炸危险的危险位置

- 把任何连接器连接到设备或从设备中拔下之前，请一定要先关闭电源。
- 在使用 USB 主机接口前，确认 USB 电缆已与 USB 座连接。

如果不遵守这些说明，将会导致死亡、严重伤害或设备损坏。

### 连接 A 型 USB 座

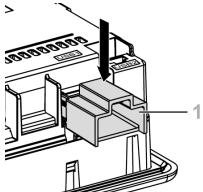
| 步骤 | 操作  |
|----|---|
| 1  | <p>将 USB 座连接到主面板的 USB 主机接口上。将 USB 座的上突舌钩住主面板的连接孔，然后如下图所示插入下突舌以固定 USB 座。</p>  <p>1 USB 座</p> |

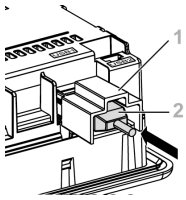
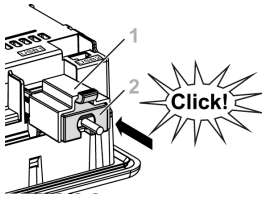
| 步骤 | 操作   |
|----|--|
| 2  | <p>将 USB 电缆插入 USB 主机接口。</p>  <p>1 USB 座<br/>2 USB 电缆</p>                          |
| 3  | <p>加上 USB 护盖以使 USB 电缆固定到位。将 USB 护盖插入 USB 固定架的滑片中。</p>  <p>1 USB 座<br/>2 USB 盖</p> |

### 取下 A 型 USB 座

抬起 USB 座的滑片，然后卸下 USB 护盖。

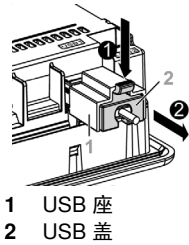

## 连接 mini B 型 USB 座

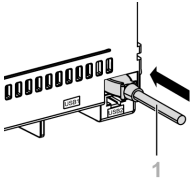
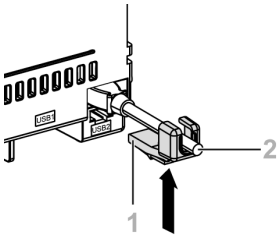
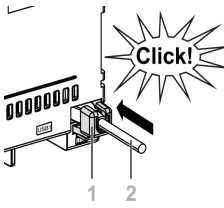
| 步骤 | 操作  |
|----|---|
| 1  | <p>将 USB 电缆插入 USB 主机接口。</p>  <p>1 USB 电缆</p>               |
| 2  | <p>加上 USB 座以使 USB 电缆固定到位。</p>  <p>1 USB 座<br/>2 USB 电缆</p> |
| 3  | <p>将 USB 座插入滑片中。</p>  <p>1 USB 座<br/>2 USB 电缆</p>         |

## 取下 mini B 型 USB 座

按压 USB 座的滑片然后取下 USB 座。

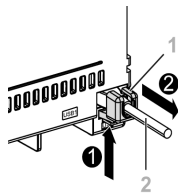

- 1 USB 座
- 2 USB 电缆



## **Contact**

Visit <http://www.proface.com.cn> for your nearest Pro-face affiliate.

Printed in